

STAINLESS STEEL CONDUIT HUBS

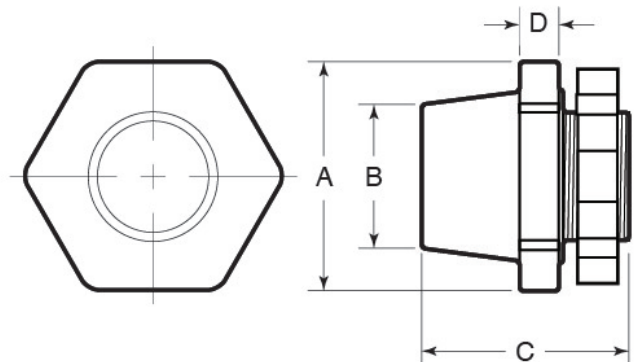

APPLICATION

- Heavy-duty, cast CF8M (316 SS)
- Designed for use with threaded conduit
- Provide a means of connecting conduit to various enclosures and/or for terminating electric circuits
- Neoprene "O" ring provides a weather proof seal
- Specially designed locknut (316 SS) grips firmly for secure installation
- Manufactured in stainless steel to help prevent corrosion
- Can be installed using ordinary hand tools and require little maintenance or repair
- Provided in a bright, polished finish that does not require touch up or painting

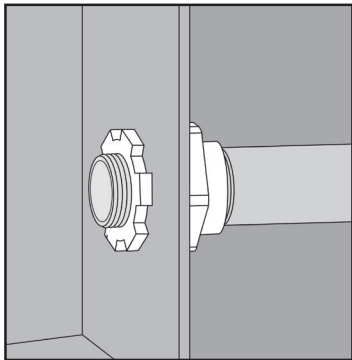

PRODUCT DETAILS

Material:

- Body: CF8M (316 SS)
- Locknut: 316 SS (½" – 1"); CF8M (1¼" – 4")
- O-Ring: Neoprene

Country of Origin:

100% Made in USA

Part Number	Size	Weight/ 100 (lbs.)	Dimension (in.)			
			A	B	C	D
7050-HUB	½ in.	20	1.31	1.07	1.32	0.25
7075-HUB	¾ in.	31	1.63	1.27	1.50	0.31
7100-HUB	1 in.	45	1.88	1.54	1.75	0.31
7125-HUB	1-¼ in.	71	2.25	1.95	1.81	0.38
7150-HUB	1-½ in.	85	2.56	2.23	1.81	0.38
7200-HUB	2 in.	112	3.06	2.65	1.85	0.38
7250-HUB	2-½ in.	190	3.60	3.20	2.40	0.42
7300-HUB	3 in.	331	4.50	3.89	2.75	0.50
7400-HUB	4 in.	453	5.38	4.97	3.00	0.56

